

ATTENTION:

The program you are installing involves multiple cartons. Below are the instructions for installing the components in the proper order. For ease in installation, please make sure the order is followed.

Please review all instructions before beginning your installation.

NOTE: ALL planogram sets should start with the bottom shelves.

- Order of Installation
- 1 Power Zone® Kwik-Set™ Self-facing System
 - 2 P.O.P. Security™ Under-Shelf Invisi-Shield® System

20190409

1
Power Zone® Kwik-Set™
Self-facing System

INSTALLATION INSTRUCTIONS:

- Begin installation on the lowest shelf
- Always begin shelf sets from the left

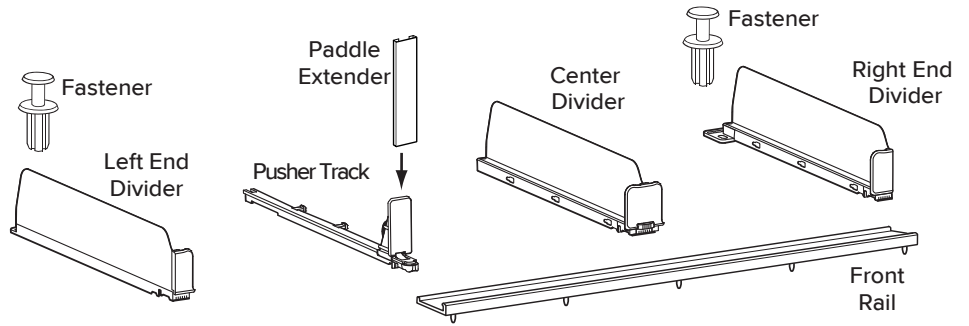

STEP 1
Front Rail

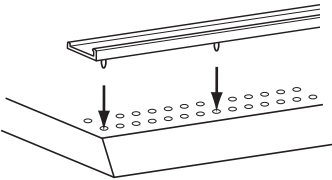

Align Front Rail with shelf edge and insert pins into front set of shelf holes.

STEP 2A
Left End Divider

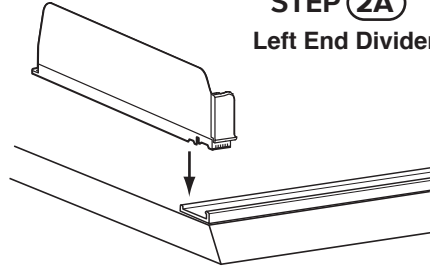

Insert Left End Divider onto Front Rail.

STEP 2B
Fastener

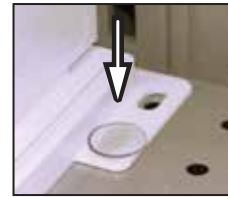

Insert Fastener through holes of Left End Divider and shelf.

STEP 3A
Center Divider

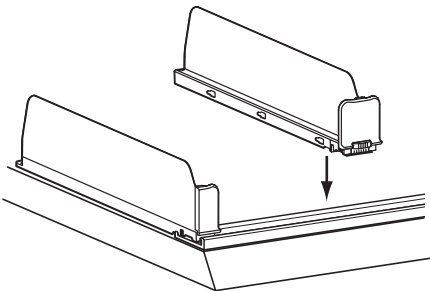

Insert Center Rail Divider onto Front Rail.

STEP 3B
Position Center Divider

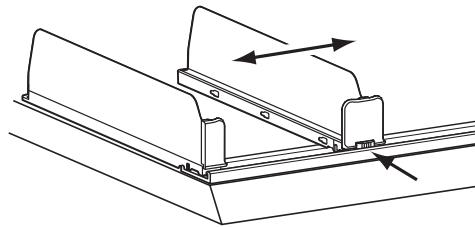

Push in button to slide Center Divider left to right.

STEP 3C
Divider Spacing

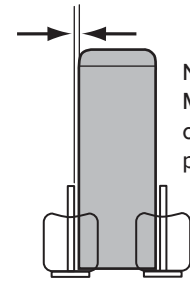

FRONT VIEW

No contact. Minimum clearance on each side between product and divider.

STEP 4
Pusher Track

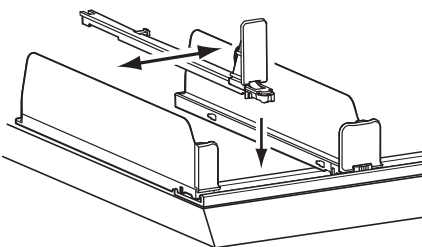

Place Track between Dividers. Push straight down on Paddle to clip into place. To adjust, slide Track left to right.

STEP 5
Paddle Extender

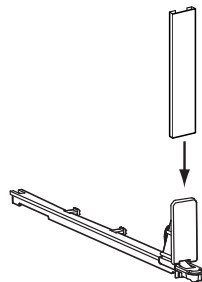

Attach Paddle Extenders by aligning opening on extender with paddle and pushing down to lock in place.

STEP 6A
Right End Divider

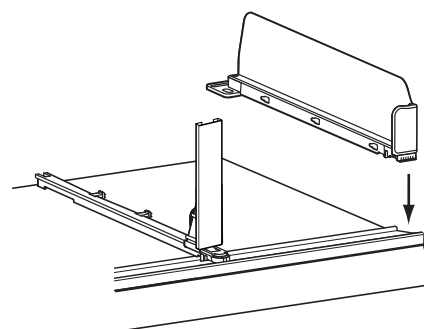

Insert Right End Divider onto Front Rail.

STEP 6B
Fastener



Insert Fastener through holes of Right End Divider and shelf.

2
P.O.P. Security™
Under-Shelf
Invisi-Shield®
System

① **NOTE:** If installing on more than one shelf, start with the bottom-most shelf. Clear product from upper mounting shelf to allow access to holes in shelf.

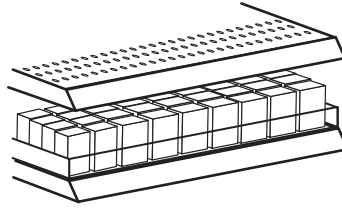

② Allow minimum 1/2" vertical space between product and upper shelf for Invisi-Shield™ panel clearance.

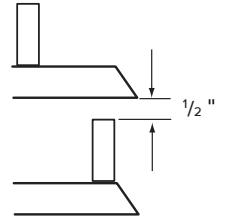

Tools Needed:
• Phillips Screwdriver

③ Installation Pins must be inserted into the Flipper Nut™ at the ends.

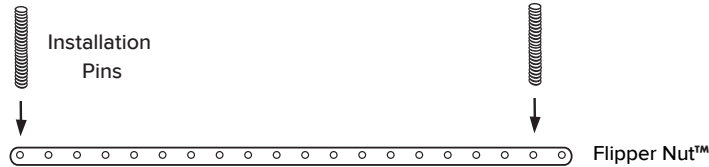

④ Slide all Panels into lower track of the Rail.

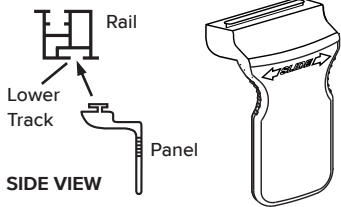

⑤ Slide Flipper Nut™ with Installation Pins into top track of the Rail.

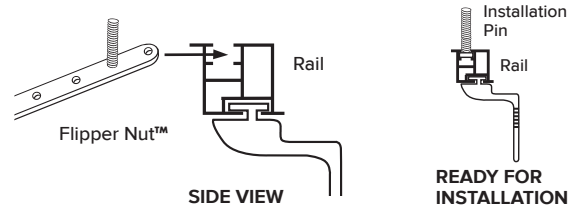

⑥ Align Installation Pins in the Flipper Nut™ to the holes in the shelf. **NOTE:** Flipper Nut™ slide easily in the track. Keep Rail level at all times to maintain Flipper Nut™ position.

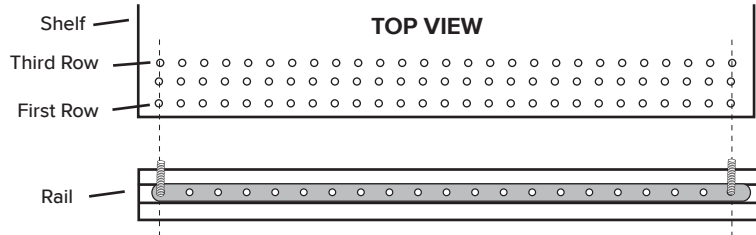

⑦ Place Rail assembly under shelf. Align the Installation Pins to the rear set of holes (**THIRD ROW**) at the front of the shelf. **NOTE:** Verify rail is positioned between shelf side supports.

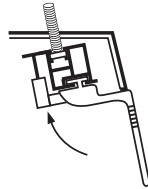

⑧ Push Installation Pins through the holes and hold the Rail flush against the bottom of the shelf. **NOTE:** For balance, it is best to hold the rail at the center.

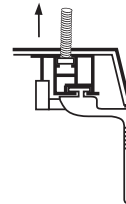

⑨ Position two screws around the center of the shelf as shown in diagram below. **Leave the ends open for now.** Install two screws into shelf and down into Flipper Nut™. After screws are installed, unscrew Installation Pins.

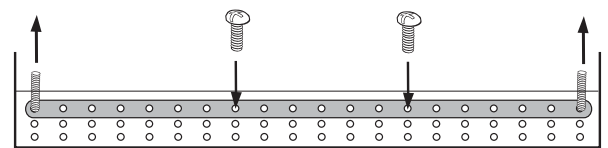
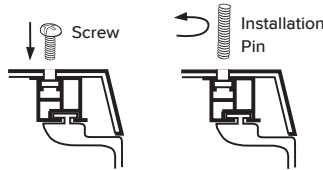

⑩ Slide the clear Panels left or right to ensure all products are accessible through the opening. If any of the products are too wide to be removed easily, continue to step 11. If all are accessible, go to next page to install end panels.

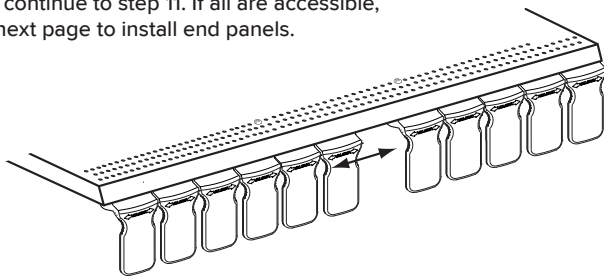

REMOVING PANELS FOR WIDE PRODUCT.

OPTIONAL

⑪ Pull down on the end Panel to bend Rail so that one Panel can be slid out of the Rail.

